

± 111,657 SF

FOR SALE

Premier Manufacturing Facility

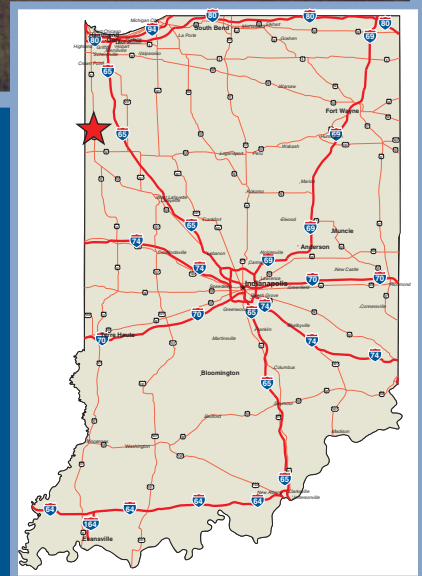

TURLEY
MARTIN
TUCKER

Commercial Real Estate Services

For more information, contact:
Colliers Turley Martin Tucker
Larry Lane
(317) 639-0467
llane@ctmt.com

Michael W.M. Weishaar
(317) 639-0494
mweishaar@ctmt.com

Ross Industrial Park
102 East Bailie Street
Kentland, Indiana

- 111,657 Square Feet
- 29.32 Acres
- Rail is Adjacent to Property
- Wet Sprinkler System
- Heavy Power

The information contained herein was obtained from sources we consider reliable. We cannot be responsible, however, for errors, omissions, prior sales, withdrawal from the market or change in price. Seller and broker make no representation as to the environmental condition of the property and recommend purchaser's independent investigation.

Ross Industrial Park

102 East Bailie Street

Kentland, Indiana

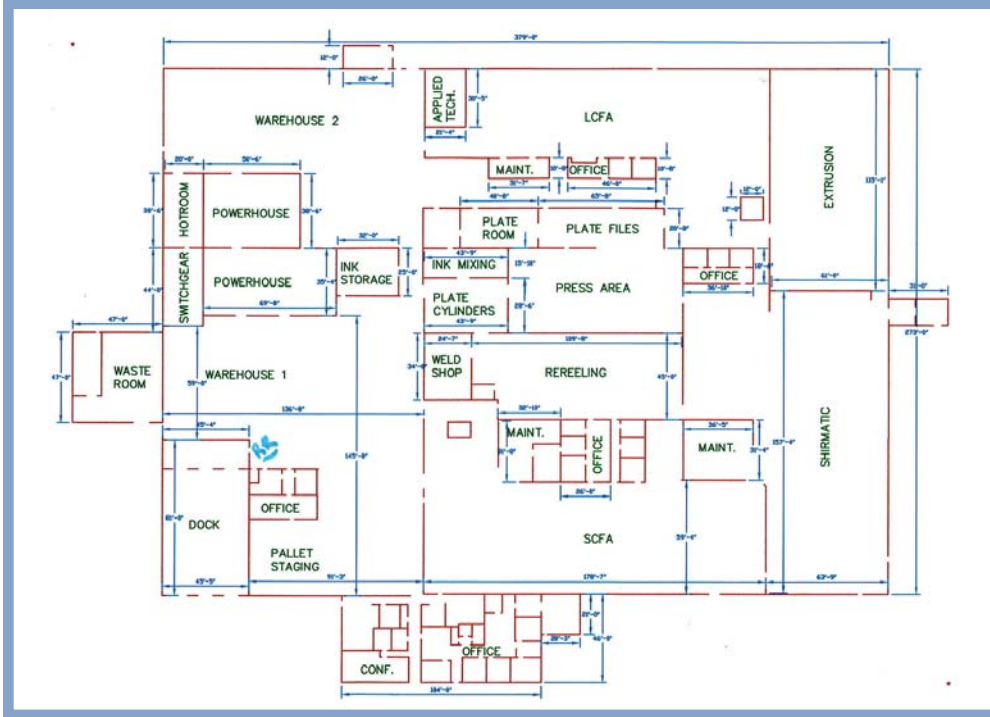

General Specifications

Building Areas: +/- 106,453 sq. ft. Warehouse
 +/- 5,204 sq. ft. Office
 +/- 111,657 sq. ft. Total

Land: +/- 29.32 acres

Zoning: (Light Industrial)

Dates Constructed: 1977/1978/1981

Construction: Block/Steel Construction

Roof:

Original (1977)

Roof - 3 plies of fiberglass felt w/vaporstop #298 roof deck vapor barrier and gravel surface. Roof to comply with 20yr fiberglass specification 323-IGD. Roof insulation - 2" fiberglass insulation for office and roof area of col. line 4, all other roof insulation to be 1- 1/2" fiberglass

Addition (1978)

Roof - Class I, FM approved, Owen Corning Spec. No. 323 I.G.D Roof w/2 Layer vapor barrier over 2 - 1/4" fiberglass insulation w/insul. relief vent. One per 1,000 SF over 1 - 1/2" type "B", 20 Ga. Metal Deck.

Addition (1981)

Roof - Class I, IRI Approved, Owens Corning, Gravel Top, Spec. NO. 323 IGD Roof w/2 Layer vapor barrier over 2 layer fiberglass insul., w/ insul. relief vents over 1- 1/2" type "B", 20 Ga. Metal Deck

Fire Protection: Wet System and Pressure Boost

Ceiling Height: +/- 21' - +/- 10'

Floor: 5" to 6" concrete

Loading: 4 docks
 I grade level drive-in door

Rail: Adjacent to property

Electrical Service: (3) 1,000 KVA, 480/3/60Hz

Lighting: Highbay metal halide / Fluorescent / Sodium Vapor

Heat: 13 Airhandlers - cold water / hot water loop

Utilities: Gas: Nipsco
 Power: Nipsco
 Water: Kentland Sewage
 Sewer: Kentland Waterworks

Miscellaneous:

18 miles west of Interstate 65
 100 miles southeast of Chicago
 100 miles northwest of Indianapolis
 Ready and willing labor force



TURLEY
 MARTIN
 TUCKER

One American Square, Suite 1300
 Indianapolis, Indiana 46282
 Telephone 317-639-0515
 Telefax 317-639-0504
 www.ctmt.com

